



SAVE THESE INSTRUCTIONS

NOTE: Check ALL parts for shipping damage. In case of shipping damage, DO NOT use. Contact Carrier/Dealer for further instruction.

SAFETY SUMMARY

The following recommendations are made for safe installation and adjustment of the Ratchet Replacement Articulating / Elevating Legrest:

GENERAL WARNING

DO NOT install or use this kit without first reading and understanding this instruction sheet. If you are unable to understand the Warnings, Cautions or Instructions, contact a healthcare professional, dealer or technical personnel before attempting to install this kit - otherwise, injury or damage may occur.

DO NOT step or stand on footrests; it could cause the chair to tip over resulting in injury.

INSTALLATION WARNING

After making adjustments and BEFORE use, make sure all attaching hardware is securely tightened.

The Ratchet Replacement Kit consists of the following:

DESCRIPTION	QUANTITY
Ratchet Body	2
Ratchet Bar	2
Ratchet Handle	2
Nylon Washer	2
Acorn Nut	2
Cam	2
Spring	2
Snap Ring	2
Spacer	2
Domed Push Cap	2

Have the following tools available:

Hammer
Punch
Snap Ring Tool

REMOVING EXISTING RATCHET ASSEMBLY (FIGURE 1)

NOTE: Note location and orientation of ratchet assembly BEFORE removing for installation of NEW ratchet kit.

- Determine how the ratchet handle is secured to the legrest.
- Perform one (1) of the following:

If the ratchet handle is secured with a Roll Pin:

- Use a hammer and a punch to remove the roll pin that secures the ratchet handle to the ratchet assembly as shown in FIGURE 1, DETAIL "A".
- Adjust the legrest assembly until the ratchet assembly including handle can be removed from the upper support tube of legrest assembly.

NOTE: When removing the ratchet assembly and handle on the articulating legrest, open the legrest assembly until you clear the drive link and link bar.

NOTE: This procedure will eliminate disassembling the upper support tube from the legrest support tube and in the case of the articulating legrest the gears will not have to be remeshed to obtain correct travel.

- Remove ratchet body and ratchet handle from upper support tube as shown in FIGURE 1, DETAIL "A".
- Discard the existing ratchet parts.

If the ratchet handle is secured with a snap ring:

- Remove the snap ring from the end of the ratchet handle using snap ring tool.
- If equipped, remove the domed push cap that secures the ratchet bar to the legrest support tube.
- Adjust the legrest assembly until the ratchet assembly including handle can be removed from the upper support tube of the legrest assembly.
- Remove ratchet body and ratchet handle from upper support tube.
- Discard the existing ratchet parts.

**RATCHET KIT WITH ROLL PIN:
ELEVATING LEGREST**

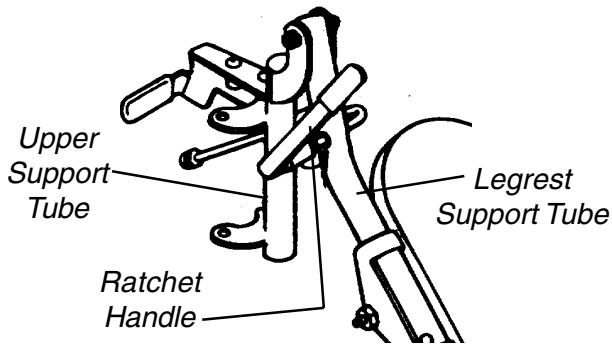

**RATCHET KIT WITH SNAP RING:
ELEVATING LEGREST**

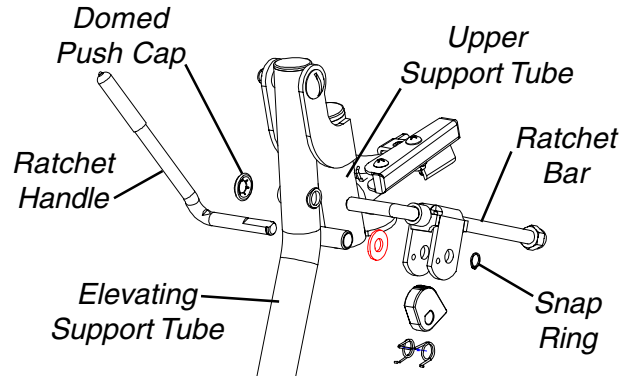

ARTICULATING LEGREST

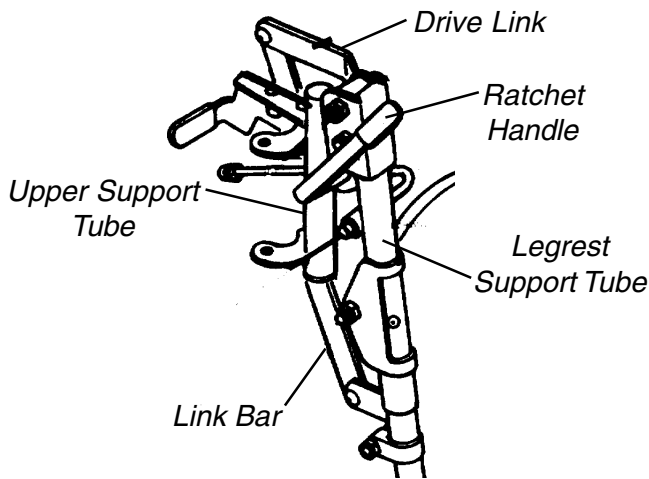

ARTICULATING LEGREST

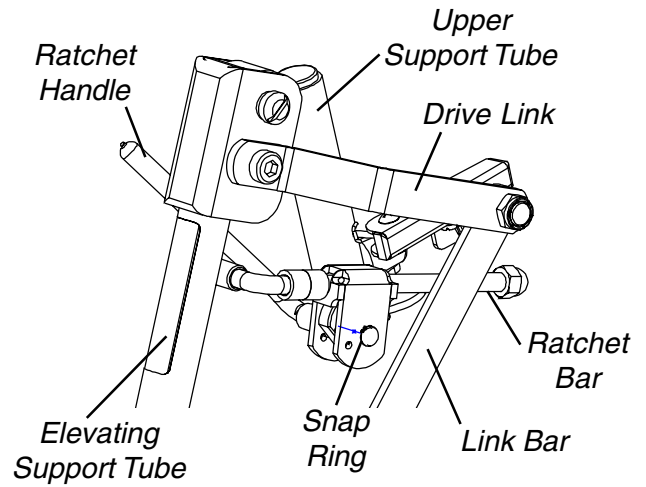

NOTE: Domed push cap not used on articulating legrest.

DETAIL "A" - DISASSEMBLING EXISTING RATCHET KIT WITH ROLL PIN

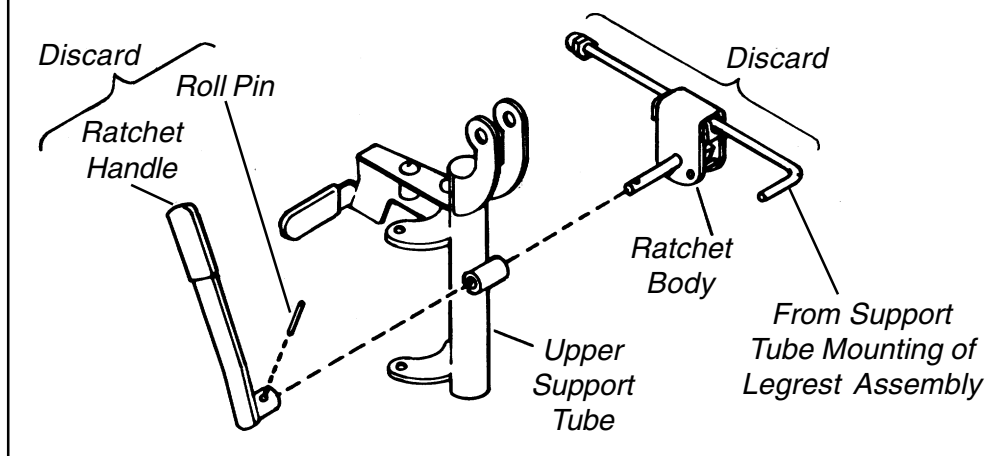

FIGURE 1 - REMOVING EXISTING RATCHET ASSEMBLY

INSTALLING NEW RATCHET KIT

Elevating Legrests (Figure 2)

1. Install ratchet handle through support tube.
2. Install nylon washer onto end of ratchet handle.
3. Install spring into ratchet body. Snap the spring clips into the spring clip mounting holes of the ratchet body.
4. Insert the cam into the ratchet body against the spring ensuring that the teeth on the cam are facing up as shown in DETAIL "A", FIGURE 2.

NOTE: The pointed end of the cam should face the rear of the wheelchair.

5. Line-up the holes in the spring with holes in the cam and the ratchet body.

NOTE: The ratchet body should be on the INSIDE of the legrest support tube with the spring clip mounting holes facing toward the front of the wheelchair.

6. While holding the cam in place, install the ratchet handle through the ratchet body, spring, cam, spring and ratchet body as shown in DETAIL "B", FIGURE 2.
7. Using snap ring tool, install snap ring into groove on end of ratchet handle to secure ratchet.
8. Install the short end of the ratchet bar into hole on elevating support tube.
9. Perform one (1) of the following:
 - A. For ADULT WHEELCHAIR with Elevating Legrests, install NO spacers on the ratchet bar.
 - B. For HEMI WHEELCHAIR with Elevating Legrests, install one (1) spacer on the ratchet bar.
10. Open legrest as far as possible.
11. Pull down on ratchet handle and insert ratchet bar into the ratchet body.
12. Work the ratchet bar into the ratchet body while closing the legrest at the same time.
13. Secure ratchet bar with the acorn nut.
14. Secure ratchet assembly by installing domed push cap on short end of ratchet bar.

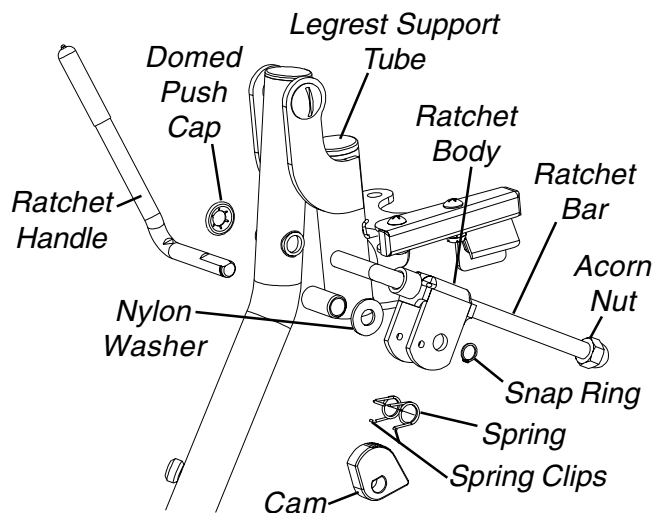

DETAIL "A" - CAM POSITION

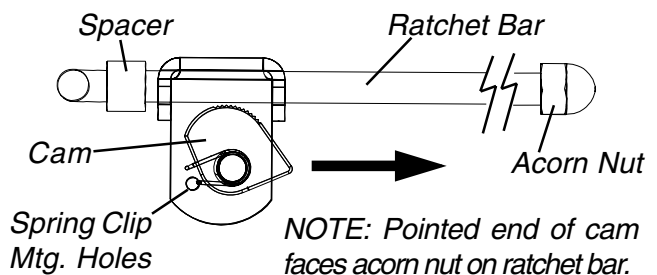

DETAIL "B" - CROSS SECTION

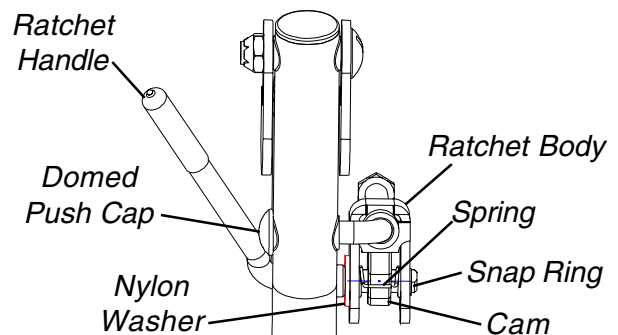

FIGURE 2 - INSTALLING NEW RATCHET KIT - ELEVATING LEGRESTS

Articulating Legrests (Figure 3)

1. Install ratchet handle from outside of legrest through upper legrest support tube.
2. Install nylon washer onto end of ratchet handle.
3. Install spring into ratchet body. Snap the spring clips into the spring clip mounting holes of the ratchet body as shown in DETAIL "A", FIGURE 3.
4. Insert the cam into the ratchet body against the spring ensuring that the teeth on the cam are facing up as shown in DETAIL "A", FIGURE 3.
5. Line-up the holes in the spring with holes in the cam and the ratchet body.

NOTE: The ratchet body should be on the INSIDE of the legrest support tube with the spring clip mounting holes facing toward the front of the wheelchair and the pointed end of the cam facing the rear of the wheelchair.

6. While holding the cam in place, install the ratchet handle through the ratchet body, spring, cam, spring and ratchet body.
7. Using snap ring tool, install snap ring into groove on end of ratchet handle to secure ratchet.
8. Perform one (1) of the following:
 - A. For ADULT WHEELCHAIR with Articulating Legrests, install one (1) spacer on the ratchet bar.
 - B. For HEMI WHEELCHAIR with Articulating Legrests, install two (2) spacers on the ratchet bar.
9. Insert short end of ratchet bar into hole on elevating support tube ensuring that the short end of the ratchet bar is pointing toward the OUTSIDE of the legrest.
10. Open legrest as far as possible.
11. Remove top screw and locknut from upper legrest support. Set aside for reassembly.
12. Remove upper legrest support from elevating support tube.
14. Insert ratchet bar into ratchet body.
15. Pull down on ratchet handle while working ratchet bar into ratchet body until the ratchet body is against the spacer on the ratchet bar.
16. Secure ratchet bar with acorn nut.

NOTE: When reinstalling upper legrest support, close legrest as far as possible and ensure that the ratchet body is against the spacer on the ratchet bar.

17. Close legrest as far as possible.
18. Reinstall upper legrest support to lower legrest support ensuring that the gears mesh.
19. Reinstall screw and locknut to secure legrest support. Securely tighten.

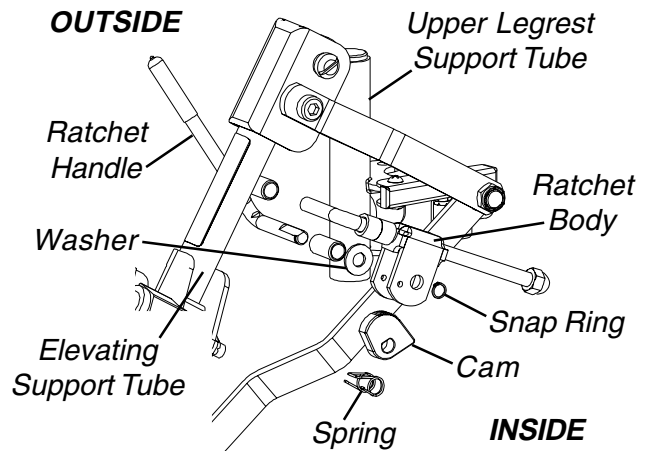

DETAIL "A" - CAM POSITION

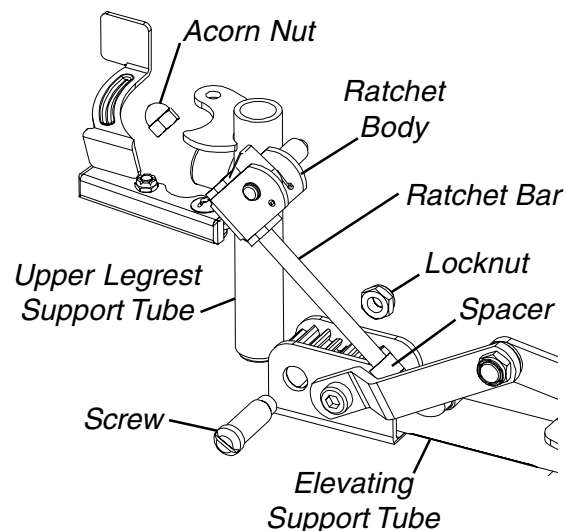
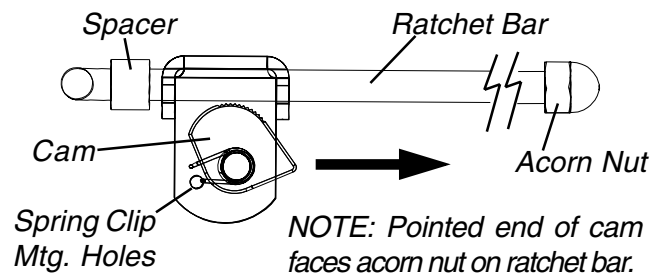

FIGURE 3 - INSTALLING NEW RATCHET KIT ARTICULATING LEGREST

**CORRECT ASSEMBLED POSITION
FOR COMPLETE TRAVEL OF
ARTICULATING LEGREST (FIGURE 4)**

1. The ADULT, after it is mounted to the chair frame, will be at about a 30° angle.
2. The HEMI, after it is mounted to the chair frame, will be at about a 45° angle.

NOTE: Check legrest for full travel and locking capability before use.

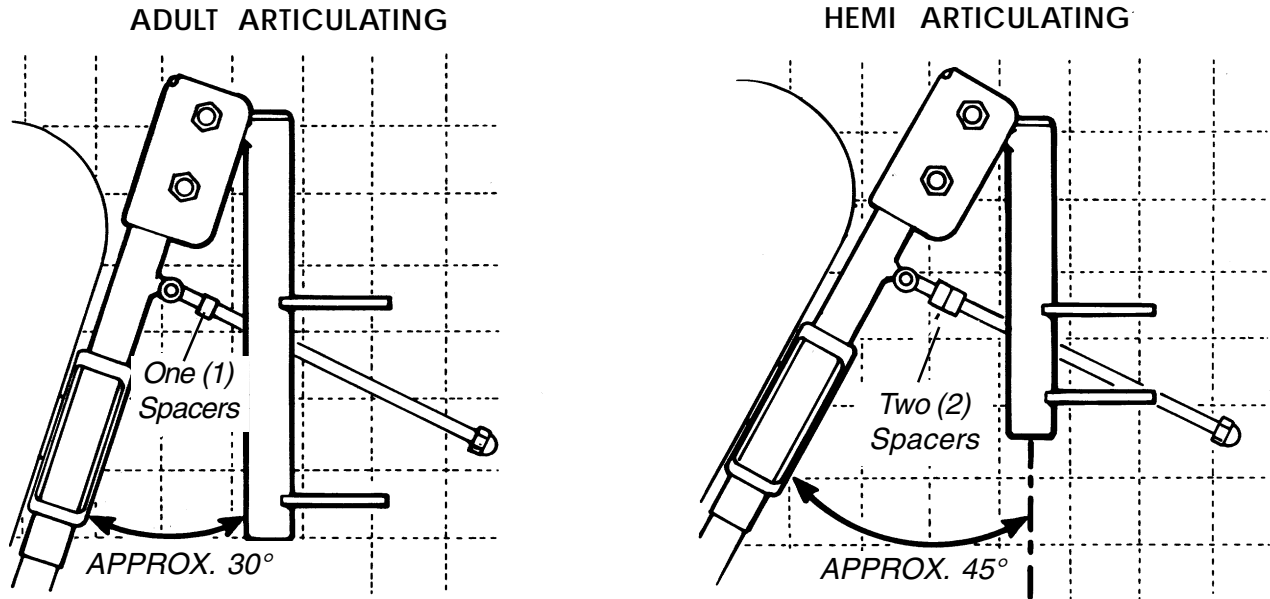

FIGURE 4 - ASSEMBLY OF THE ARTICULATING LEGREST



Yes, you can.™

Invacare Corporation www.invacare.com

USA
One Invacare Way
Elyria, Ohio USA
44036-2125
800-333-6900

Canada
5970 Chedworth Way
Mississauga, Ontario
L5R 3T9, Canada
905-890-8838

Invacare and "Yes, you can" are trademarks of Invacare Corporation.
© 2000 Invacare Corporation
Form No. 93-159 Part No. 1042798 Rev C (1) 9/00